

EASYSKAN+ SERIES

The intelligent scanner
for profitable cutting and sorting



High performance, low investment - The new midrange scanner from WEINIG

The WEINIG LuxscanLine EasyScan+ is a new addition to the innovative and completely redeveloped product portfolio of WEINIG LuxscanLine scanners. The EasyScan+ features state-of-the-art sensor technology at an affordable level. Together with the OptiCore software this provides simplicity, accuracy and high reliability.



Optimizing – the one, two, three

Step 1. LuxscanLine scanners use multiple sensor technology such as laser cameras, colour cameras and xray*. Suitable for many applications your WEINIG expert will advise on the appropriate scanner based on the wood species, surface quality and required performance. Our goal is to achieve the best possible information quality for each customers' application.

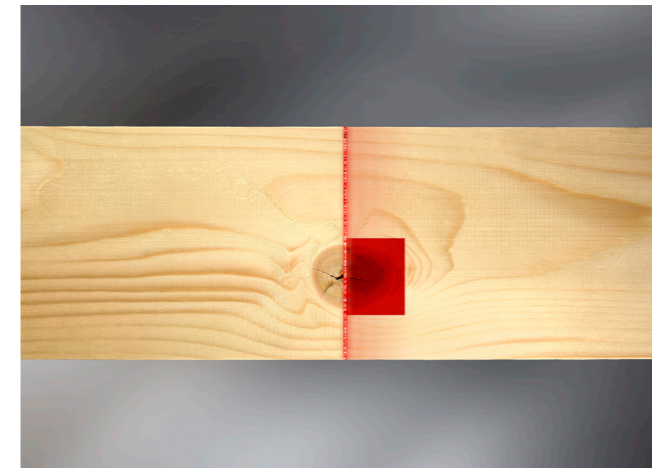

Step 2. In the next step, image processing, the highly developed LuxscanLine OptiCore software takes over. It can see and identify different defects as well as colour variations on the board. Quality data from the multiple sensors allows for optimal data processing and defect identification.

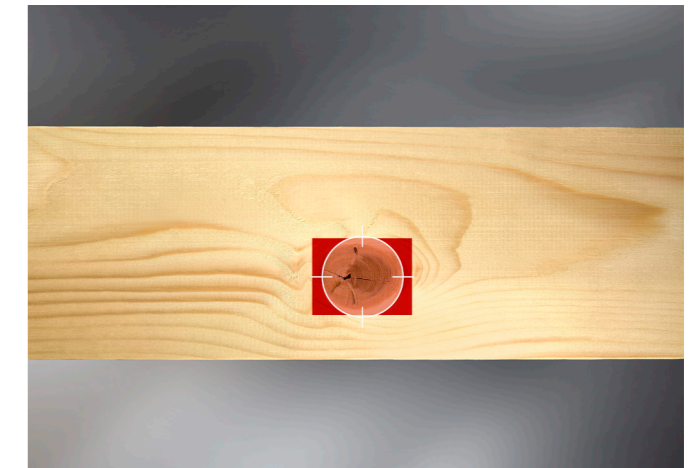

Step 3. The optimization from the powerful OptiCore software provides the best solution for cross-cutting, ripping* or sorting. It takes into account various customer requirements and quality demands. Based on the exact characteristics identified during image processing, the board is optimized

according to customer requirements. There are unlimited possibilities in the definition of products and qualities. By dividing the products into diverse zones complicated qualities can also be easily dealt with. Therefore multiple end products can be produced.

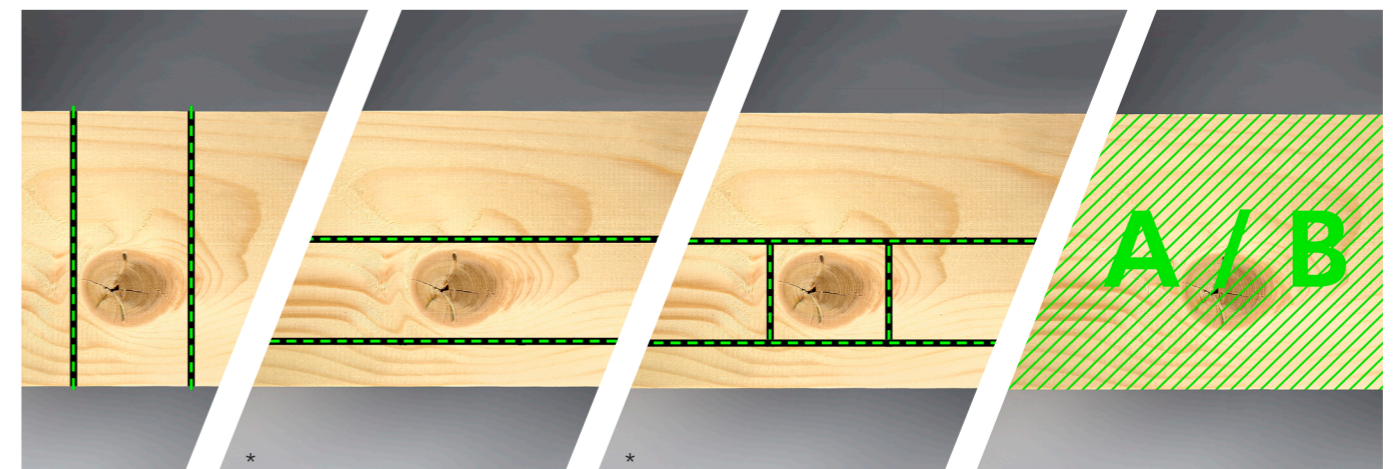

* not available in all scanner models

High Quality components

High quality, industrial grade sensors and modern construction methods make EasyScan+ the ideal platform for stable production performance while reducing costs. Thanks to a small footprint not only is it the perfect solution for upgrading existing lines, but also a useful addition in new optimizing lines. Scanner based optimising is now available for companies of all sizes.

No compromise

The EasyScan+ has been designed to operate in combination with 1 or 2 crosscut saws but is available for other applications as well. Simplified design, proven technology combined with user friendly automatic camera positioning allows for the ideal camera position. Together with solid construction in a compact frame, mechanization through the scanner is stable and reliable.

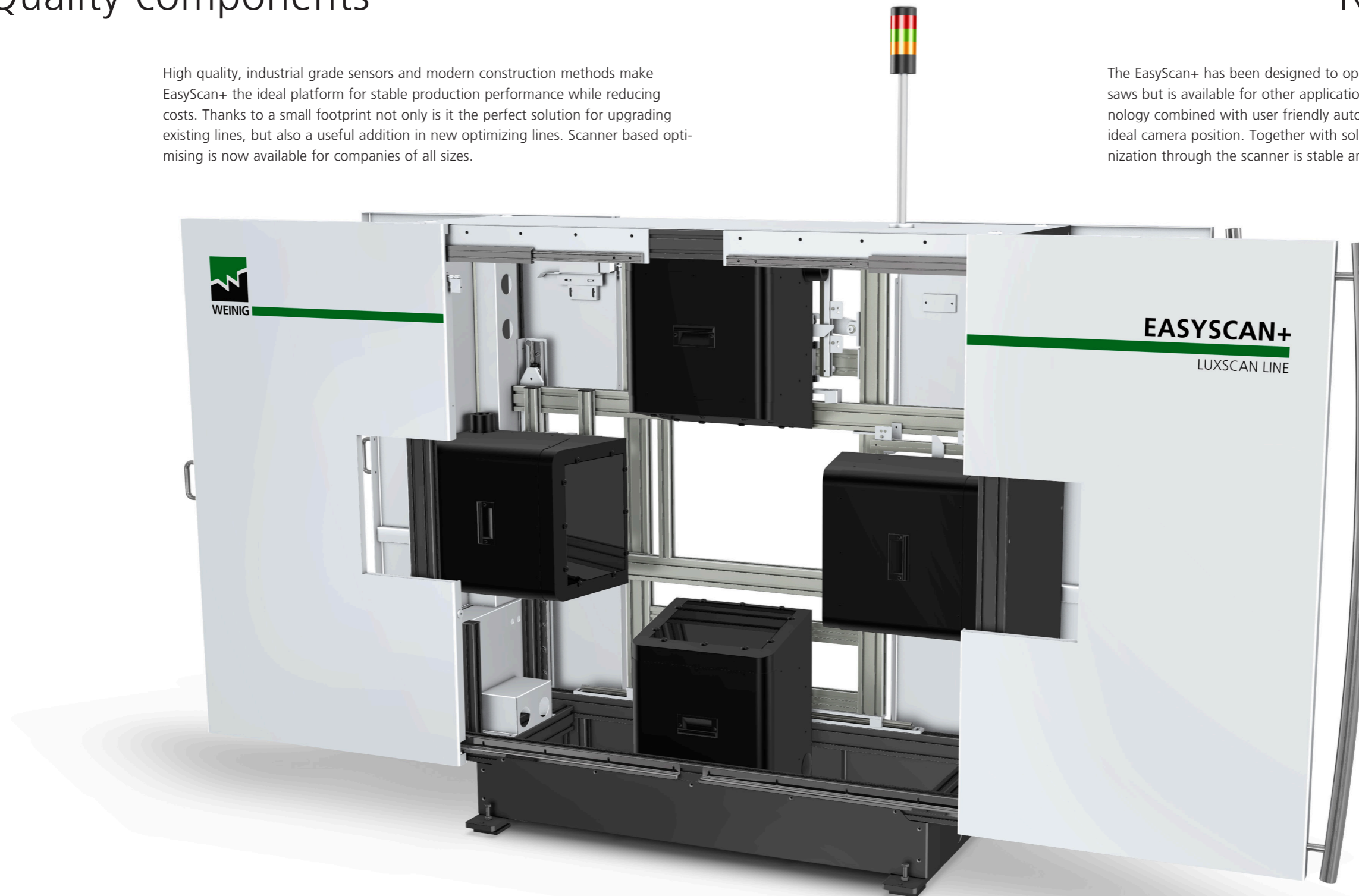

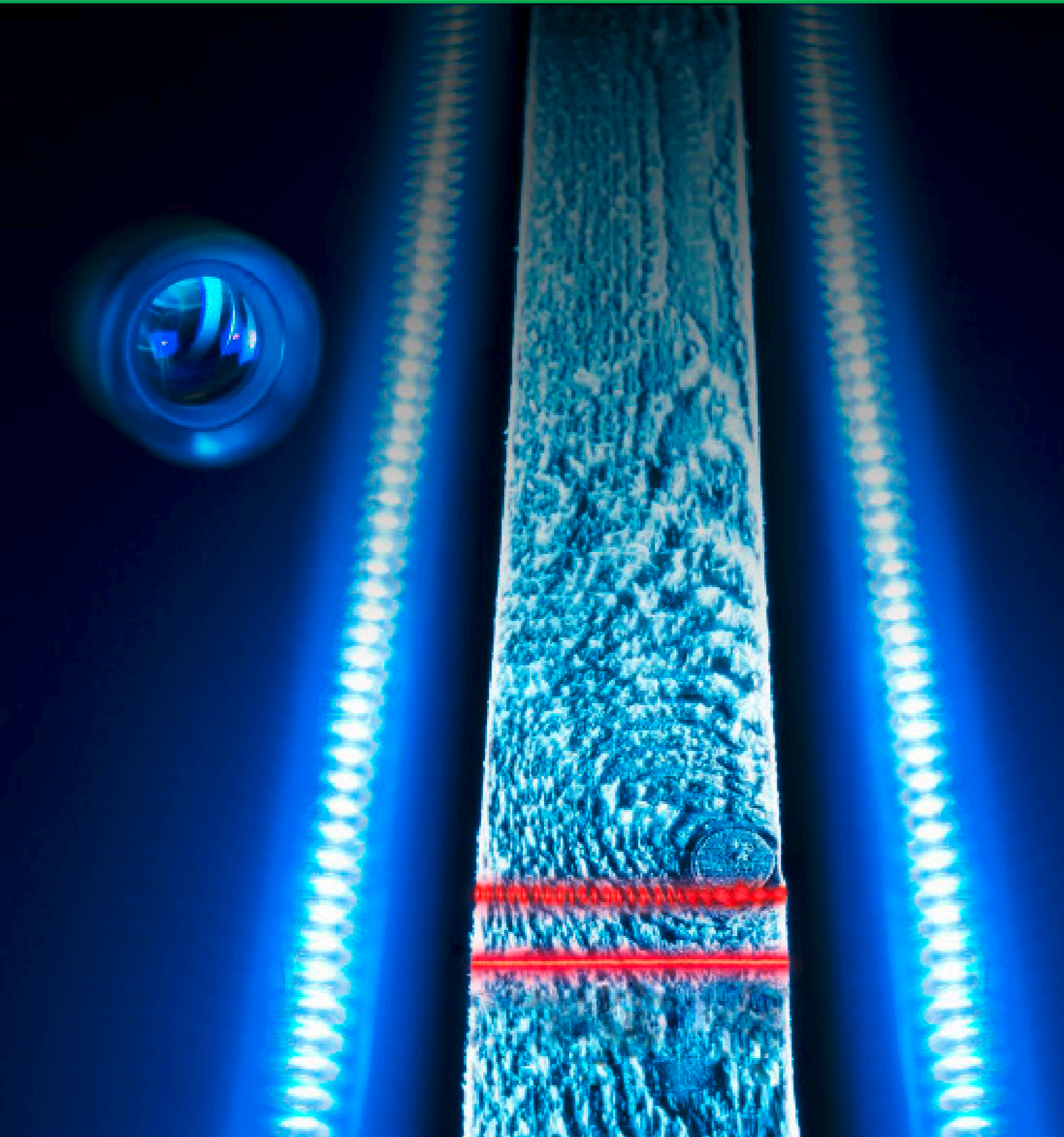

The sensors: Key to success

All our systems are fitted with laser and color cameras as standard. With the detection capabilities of both cameras combined the best results are guaranteed. Continuous development in these industrial sensors ensures performance is continually improving. Using this technology it is possible to identify defects such as knots, pith, cracks etc. The improved laser system also allows detection of 3D surface defects such as holes, wane and edge defects. All sensors are protected within an sealed climate control system.

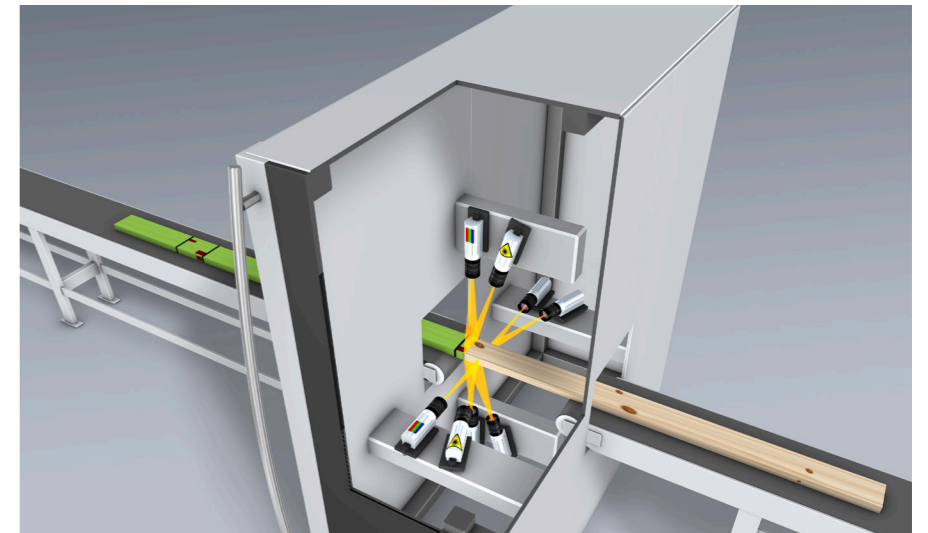

Fibre analysis - improved cut accuracy

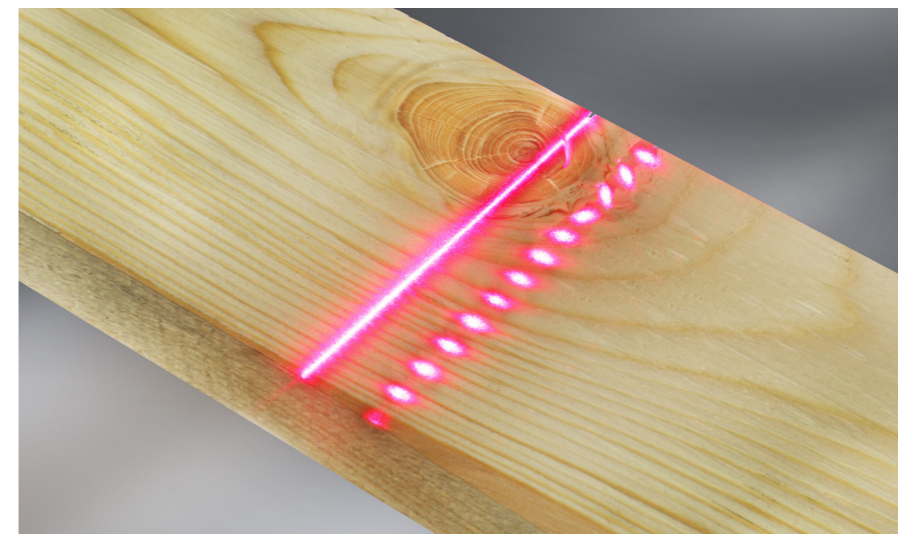

An important part of maximizing yield and profit is locating the correct cut position, especially for fingerjoint products. Dual scatter technology, consisting of one line and one dot laser provides this accuracy. While the line laser is mainly used for the detection of knots, cracks and resin pockets the additional dot lasers will improve defect detection, especially on rough surfaces. Cut positions can be improved based on angle and shape of the dots. This helps to prevent damage in fingerjoint applications and to identify weak areas in strength grading products. Both hard and softwood can be processed.

Simple adjustment is the key

The simple design of the EasyScan+ is complimented by the simple, user friendly software. However, simple does not mean lacking in performance. Minimising adjustment and calibration times increases the available production time and therefore output. Automatic camera positioning ensures the cameras are in the ideal position to achieve the best resolution and image quality. It also prevents mistakes in set-up, meaning production errors are reduced to the minimum.



Powerful optimising software

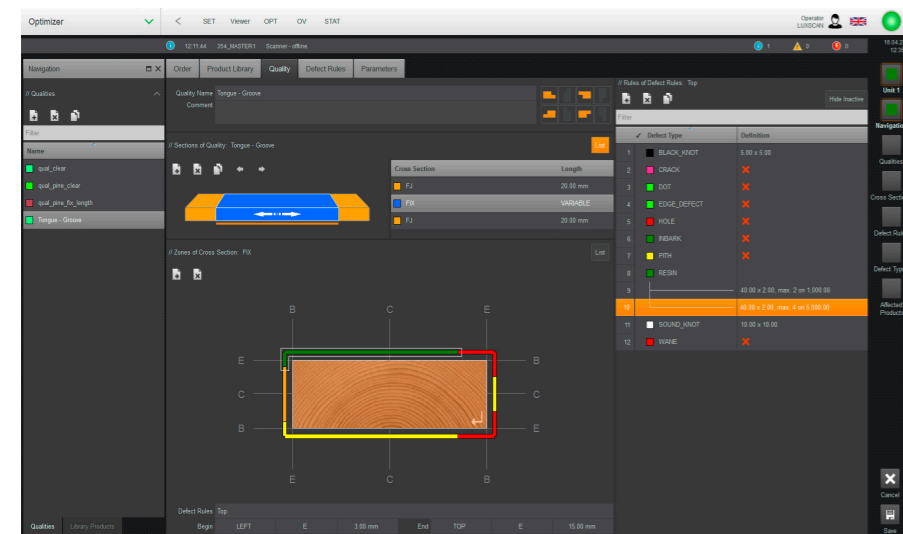

Simple optimizing is the key to efficient production management. The powerful optimizer, OptiCore, allows you to programme multiple qualities and zones, tailored to your final product requirements. Multiple products and qualities are stored in a library and can be quickly and easily combined using the "drag and drop" feature. The logical interface of the scanner improves the set-up which is simple for any operator to use. This assures for high reliability, maximum availability and excellent performance. Operating mistakes are reduced if not even eliminated.

Process optimization - for market leaders

The EasyScan+ can be effectively applied in many different applications. From simple, entry level saw lines to complex production facilities the EasyScan+ is the perfect partner, not only for today's production demands, but also for anything else that tomorrow might bring. The EasyScan+ provides the perfect platform for increased productivity with maximum control.

One scanner and one crosscut saw

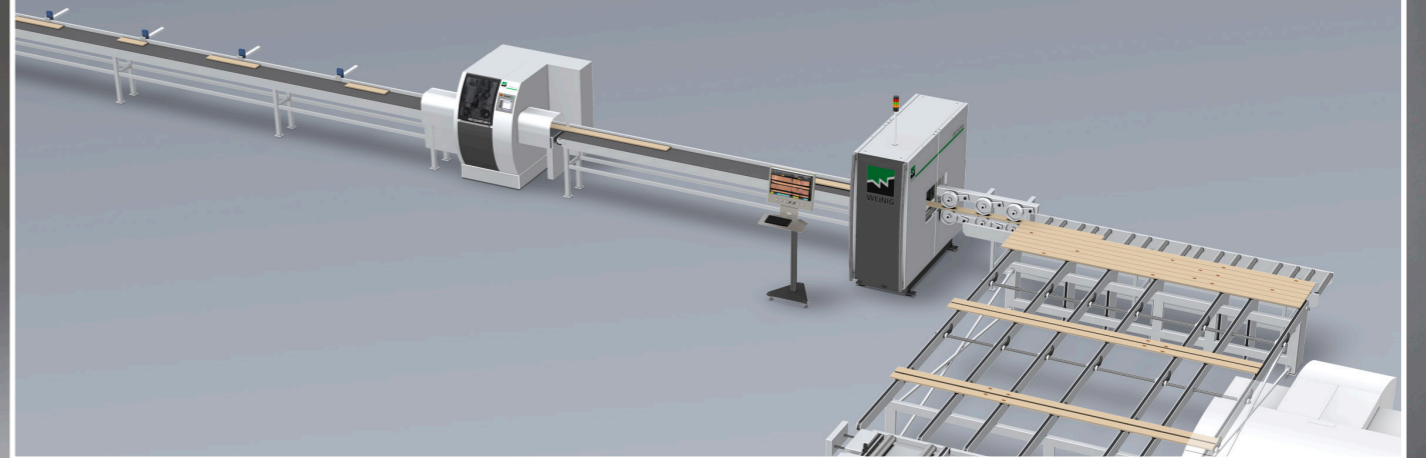

One scanner and two crosscut saws

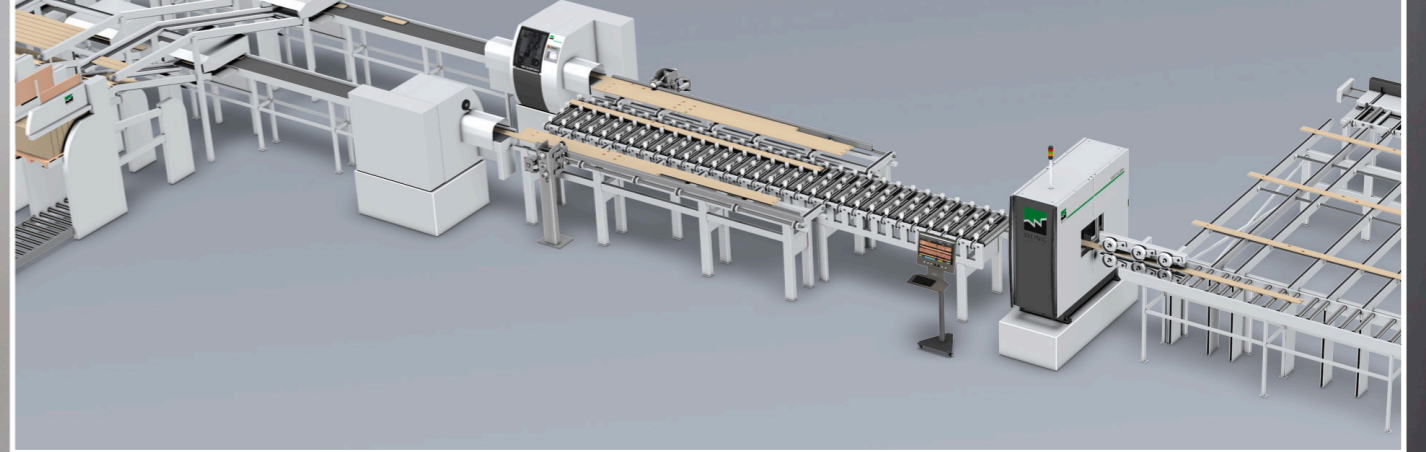

ShapeScan



The ShapeScan is the ideal option when a certain degree of bending, bow or twist is to be detected. The measurement of cup is optional. The ShapeScan T uses multiple sensors to measure transversally on any cross conveyor. The ShapeScan L measures in a longitudinal direction. The shape data can be included in the optimization so that, for example, a maximum bow per product is allowed. As a stand alone product it can be used to remove pieces out of tolerance.

OptiLink: Advanced optimizing

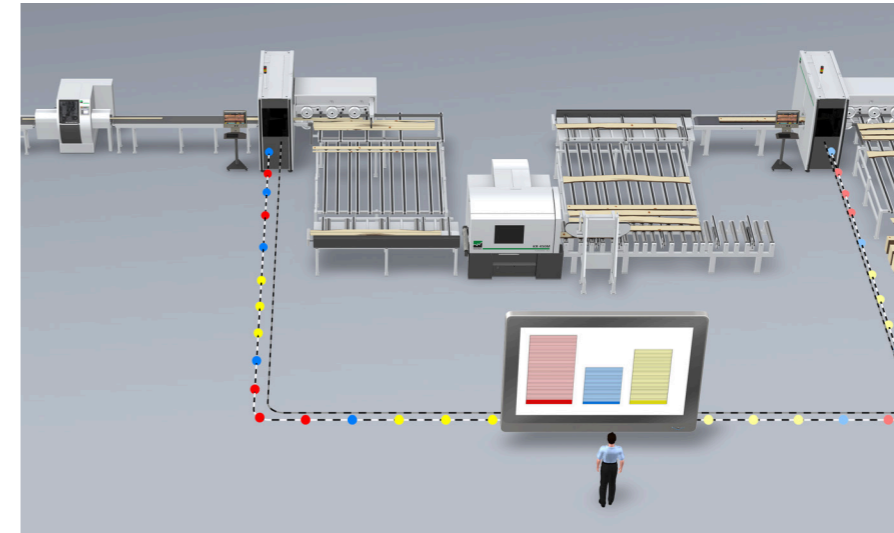

Running complex processes has always been a difficult task. Combining different applications and production lines complicates the flow of information. OptiLink has been designed to optimize production management by centralizing the information flow. With only one access point to your production, producing just-in-time is no more a complex task. OptiLink minimizes operating errors on one hand and reduces intermediate stock on the other, which is a central benefit. Connectivity to ERP systems ensures easy access and data transfer, is another.

Marking station

The perfect solution to connect a scanner to multiple existing optimizing crosscuts, without the need for complex mechanisation or where mechanical or data connection is not possible. Cuts, qualities and rotation can all be printed on each cut piece, providing the perfect identification for further processing. The marking station is also a useful addition in strength grading and sorting lines.



Front End Scanner

Front End Scanner is a system mounted behind a crosscut saw, to scan both ends of the cut pieces. With its internal contrasting defects such as pith can be detected. That information can be used to regrade pieces going to a finger-jointer or for products which are later split, minimizing rework and maximizing yield. It can be added to existing scanner lines as well as manual marking lines.



Overview of the EasyScan+ series: Standard specification and options

The table shows the standard technical specifications. For further, more detailed information according to your individual needs please contact an expert from WEINIG.

Technical Data	EasyScan+ C	EasyScan+ S
Max. speed (m/min)	120 – 180 *	50 – 180 *
Max boards/min	up to 30 *	up to 100 *
Max throughput linear m/min	100 *	100 *
Min. / Max. input length (mm)	900 – 6500 *	900 – 6500 *
Min. / Max. input width (mm)	30 - 260	30 – 260
Min. / Max. input thickness (mm)	10 – 100	10 – 100
Hardwood / Softwood	● / ●	● / ●
Working height (mm)	920 *	920 *

Standards and options (internal)

Laser camera 2 S – 4 S	●	●
Colour camera 2 S – 4 S	●	●
LED – lighting	●	●
Line laser	●	●
Fibre analysis (dot laser)	●	●
3D+	○	○
Profile module	○	○
Cooling / Heating for sealed camera boxes	● / ○	● / ○

Options (external)

Scanner mechanization	○	○
ShapeScan	○	○
Front End Scanner	○	○
Stress Grading	○	○
Moisture measurement	○	○
Marking station	○	○

* Other speeds, dimensions or working heights upon application. All scanners will be matched to customer requirements. For this reason technical details may vary. Technical changes possible. Statements and illustrations in this brochure include optional extras which are not included in the standard specifications. Covers sometimes removed for photographic purposes.

● Standard ○ Option

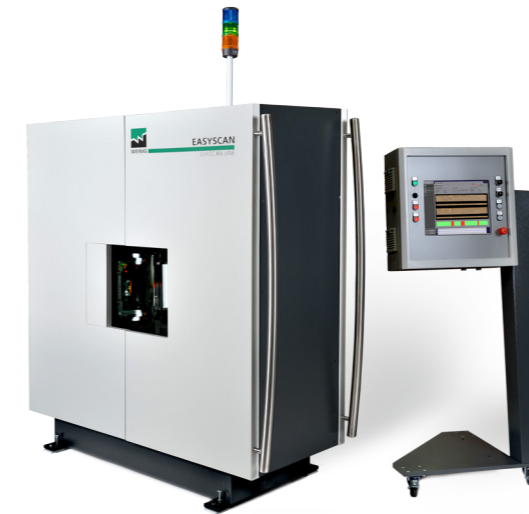

EasyScan: The economical optimizing solution

The EasyScan LuxscanLine series opens up the possibility of fully automated optimizing for any company size. Low investment costs together with simple production control provide multiple economical possibilities. With the EasyScan LuxscanLine scanning becomes affordable for everyone.

CombiScan Evo: Maximum performance and flexibility

The CombiScan Evo LuxscanLine series is the flagship of the WEINIG scanner range. Additional high end sensors in various combinations provide the perfect platform for all of today's high level production demands. The CombiScan Evo takes optimizing possibilities to a whole new level while providing maximum control and transparency in the production process.

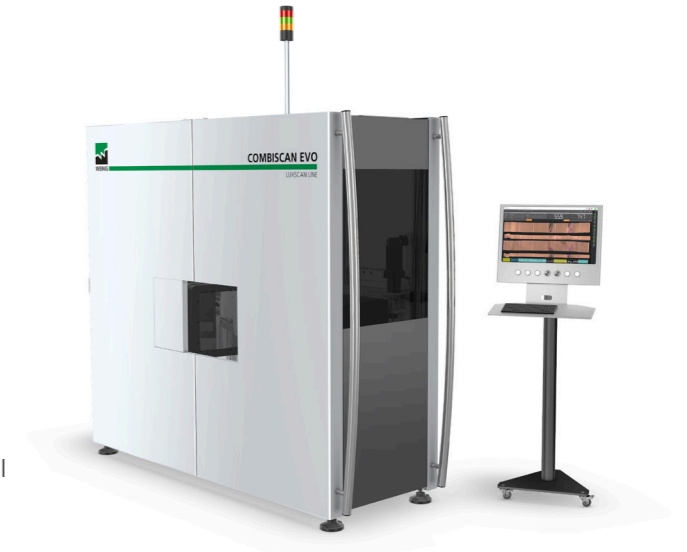

EScan strength grading

The EScan LuxscanLine marks a step into a new application for WEINIG. With EScan the product portfolio has been increased to optimized stress grading. A variety of different stress grading options is available now for the production of gluelam beams, DUO, TRIO and other strength based products. Benefit from the increases in performance and check out the multiple options and combinations with our EasyScan, Easy-Scan+ or CombiScan Evo series.

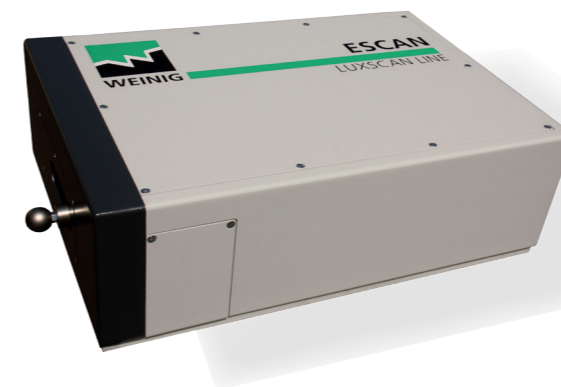

You can expect big things from us:
WEINIG – Your partner for the future.

We are here for you.

Comprehensive advice – for example on optimum process integration of your new CombiScan Evo – is standard service at WEINIG as well as a well-tested training plan with effective training sessions. Our branches in all four corners of the earth and an extensive service team guarantee rapid help where and when you need us. As you see: WEINIG offers more.



Production



Advice



Training



Service

WEINIG WORKS WOOD

Machines and systems
for solid wood processing
in WEINIG quality

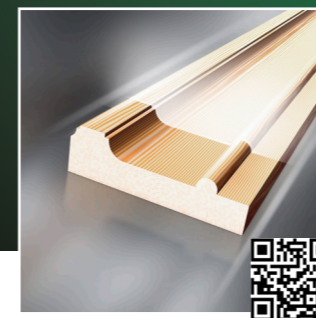

- S4S and profiling
- Automation
- Tool / grinding systems

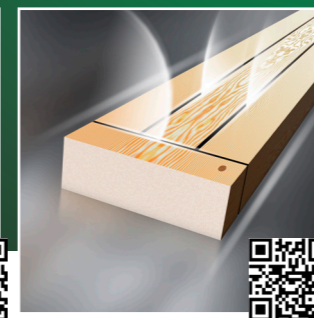

- Ripping / cross cutting
- Scanner technology
- Optimization

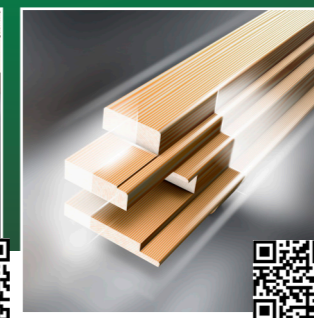

- Windows and doors
- Furniture
- Surface sections

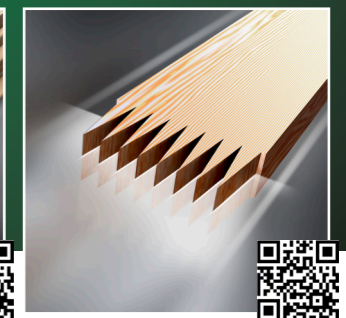

- Finger-jointing
- Tenoning
- Coping

Your expert
www.weinig.com

WEINIG OFFERS MORE



EASYSCAN+ SERIES



LUXSCAN Technologies Sarl
ZARE Ouest
L-4384 Ehlerange
Luxembourg

Telefon +352 540 416
Telefax +352 540 417
info@luxscan.com
www.weinig.com

MICHAEL WEINIG AG
Weinigstraße 2/4
D-97941 Tauberbischofsheim
Germany

Telefon +49 93 41 / 86-0
Telefax +49 93 41 / 70 80
info@weinig.com
www.weinig.com